

Air-Conditioners For Building Application

OUTDOOR UNIT

PUHY-HP-YHM-A (-BS)

CE

For use with R410A

INSTALLATION MANUAL

For safe and correct use, please read this installation manual thoroughly before installing the air-conditioner unit.

INSTALLATIONSHANDBUCH

Zum sicheren und ordnungsgemäßen Gebrauch der Klimageräte das Installationshandbuch gründlich durchlesen.

MANUEL D'INSTALLATION

Veillez lire le manuel d'installation en entier avant d'installer ce climatiseur pour éviter tout accident et vous assurer d'une utilisation correcte.

MANUAL DE INSTALACIÓN

Para un uso seguro y correcto, lea detalladamente este manual de instalación antes de montar la unidad de aire acondicionado.

MANUALE DI INSTALLAZIONE

Per un uso sicuro e corretto, leggere attentamente questo manuale di installazione prima di installare il condizionatore d'aria.

INSTALLATIEHANDLEIDING

Voor een veilig en juist gebruik moet u deze installatiehandleiding grondig doorlezen voordat u de airconditioner installeert.

MANUAL DE INSTALAÇÃO

Para segurança e utilização correctas, leia atentamente este manual de instalação antes de instalar a unidade de ar condicionado.

ΕΓΧΕΙΡΙΔΙΟ ΟΔΗΓΙΩΝ ΕΓΚΑΤΑΣΤΑΣΗΣ

Για ασφάλεια και σωστή χρήση, παρακαλείστε διαβάσετε προσεχτικά αυτό το εγχειρίδιο εγκατάστασης πριν αρχίσετε την εγκατάσταση της μονάδας κλιματισμού.

РУКОВОДСТВО ПО УСТАНОВКЕ

Для осторожного и правильного использования прибора необходимо тщательно ознакомиться с данным руководством по установке до выполнения установки кондиционера.

MONTAJ ELKİTABI

Emniyetli ve doqru biçimde naswl kullanwlaçaqwnw öqrenmek için lütfen klima cihazwnw monte etmeden önce bu elkitabwnw dikkatle okuyunuz.

PŘÍRUČKA K INSTALACI

V zájmu bezpečného a správného používání si před instalací klimatizační jednotky důkladně pročtěte tuto příručku k instalaci.

NÁVOD NA INŠTALÁCIU

Pre bezpečné a správne použitie si pred inštalovaním klimatizačnej jednotky, prosím, starostlivo prečítajte tento návod na inštaláciu.

TELEPÍTÉSI KÉZIKÖNYV

A biztonságos és helyes használatához, kérjük, olvassa el alaposan ezt a telepítési kézikönyvet, mielőtt telepítené a légkondicionáló egységet.

PODRECZNIK INSTALACJI

W celu bezpiecznego i poprawnego korzystania należy przed zainstalowaniem klimatyzatora dokładnie zapoznać się z niniejszym podręcznikiem instalacji.

PRIROČNIK ZA NAMESTITEV

Za varno in pravilno uporabo pred namestitvijo klimatske naprave skrbno preberite priročnik za namestitev.

GB

D

F

E

I

NL

P

GR

RU

TR

CZ

SV

HG

PO

SL

6

[Fig. 6.0.1]

(1)

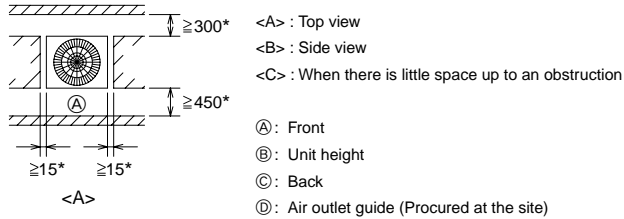

(2)

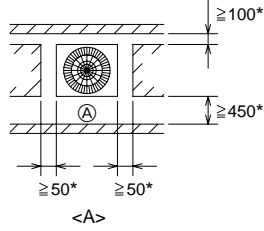

(3)

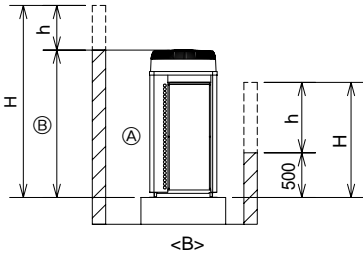

(4)

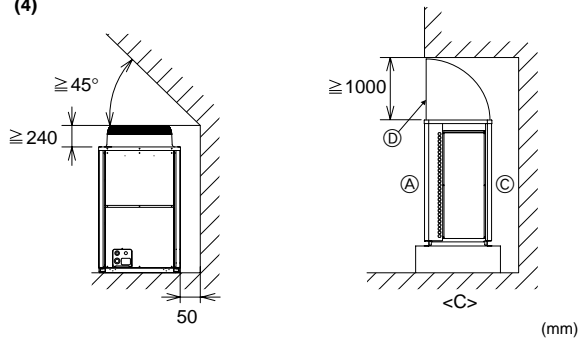

[Fig. 6.0.2]

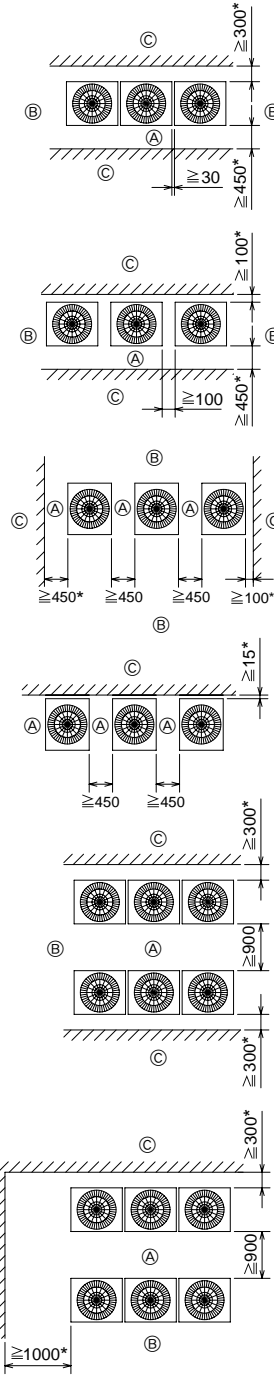

7

[Fig. 7.0.1]

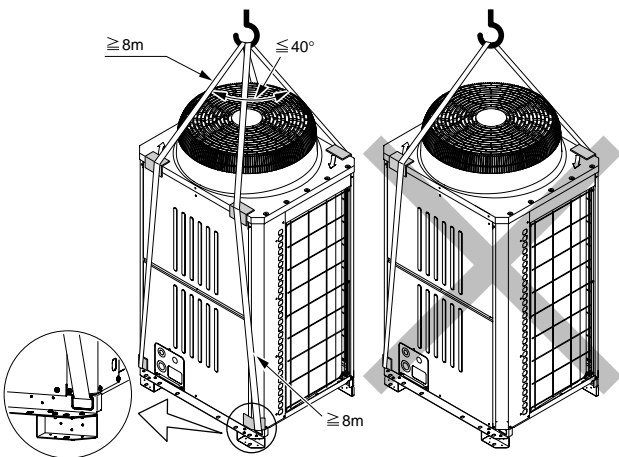

8

[Fig. 8.1.1]

<A> Without detachable leg

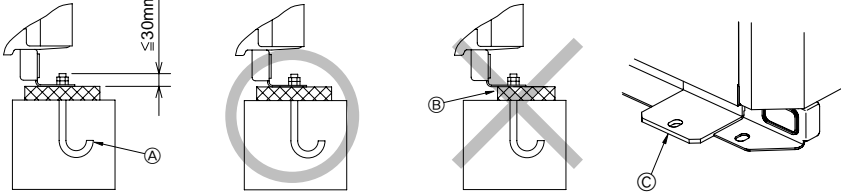

- Ⓐ: M10 anchor bolt procured at the site.
- Ⓑ: Corner is not seated.
- Ⓒ: Fixing bracket for hole-in anchor bolt (3 locations to fix with screws).
- Ⓓ: Detachable leg

 With detachable leg

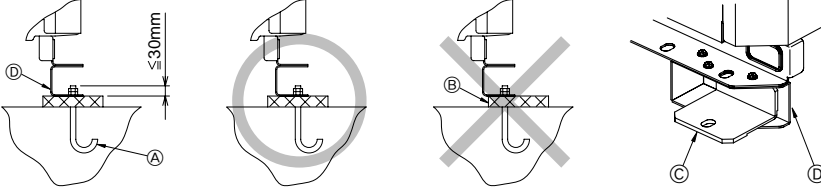

[Fig. 8.1.2]

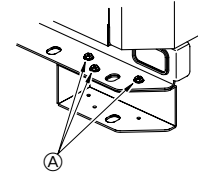

- Ⓐ: Screws

[Fig. 8.1.3]

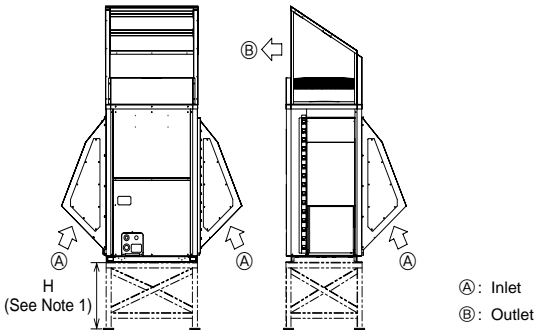

- Ⓐ: Inlet
- Ⓑ: Outlet

9

9.2

[Fig. 9.2.1]

[P200 - P250]

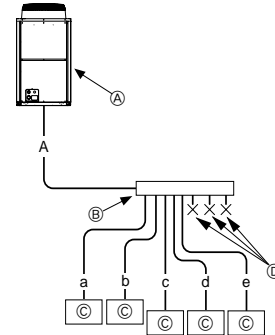
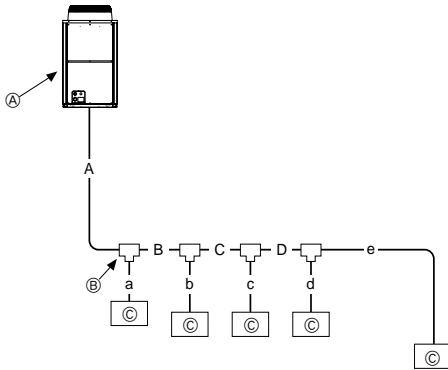

[P400 - P500]

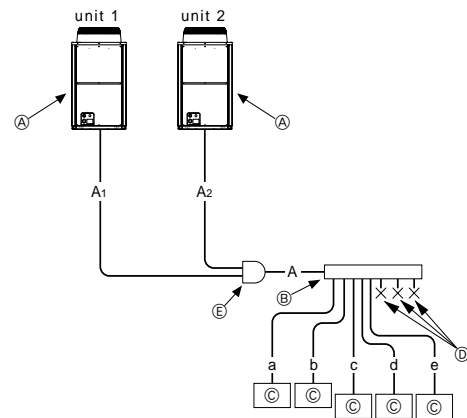
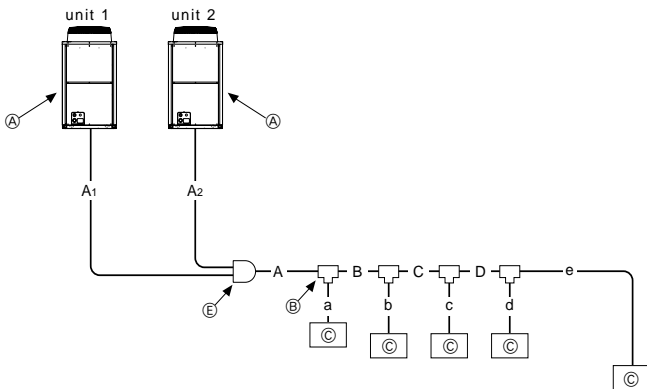

- Ⓐ: Outdoor unit
- Ⓑ: Branch
- Ⓒ: Indoor unit
- Ⓓ: Cap
- Ⓔ: Outdoor twinning kit

A (Unit: mm)

Ⓐ Outdoor model	Unit combination		A		A1		A2	
	unit 1	unit 2	Liquid pipe	Gas pipe	Liquid pipe	Gas pipe	Liquid pipe	Gas pipe
P200	-	-	ø12.7 Brazed	ø19.05 Brazed	-	-	-	-
P250	-	-	ø12.7 Brazed	ø22.2 Brazed	-	-	-	-
P400	P200	P200	ø15.88 Brazed	ø28.58 Brazed	ø9.52 Brazed	ø19.05 Brazed	ø9.52 Brazed	ø19.05 Brazed
P500	P250	P250	ø15.88 Brazed	ø28.58 Brazed	ø9.52 Brazed	ø22.2 Brazed	ø9.52 Brazed	ø22.2 Brazed

B, C, D (Unit: mm)

Total capacity of indoor units	Liquid pipe	Gas pipe
~ 140	ø9.52	ø15.88
141 ~ 200	ø9.52	ø19.05
201 ~ 300	ø9.52	ø22.2
301 ~ 400	ø12.7	ø28.58
401 ~ 650	ø15.88	ø28.58

Downstream unit model total	Ⓑ Joint
~ 200	CMY-Y102S-G2
201 ~ 400	CMY-Y102L-G2
401 ~ 650	CMY-Y202-G2
The 1st branch of P400 ~ P650	

a, b, c, d, e (Unit: mm)

Ⓒ Model number	Liquid pipe	Gas pipe
15, 20, 25, 32, 40, 50	ø6.35	ø12.7
63, 71, 80, 100, 125, 140	ø9.52	ø15.88
200	ø9.52	ø19.05
250	ø9.52	ø22.2

Ⓑ 4-Branch header (Downstream indoor unit model total ≤ 200)	Ⓑ 8-Branch header (Downstream indoor unit model total ≤ 400)	Ⓑ 10-Branch header (Downstream indoor unit model total ≤ 650)
CMY-Y104-G	CMY-Y108-G	CMY-Y1010-G

Ⓐ Outdoor model P400 ~ P500	Ⓔ Outdoor Twinning Kit CMY-Y100VBK2

[Fig. 9.2.2]

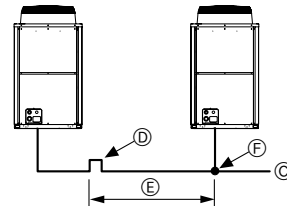
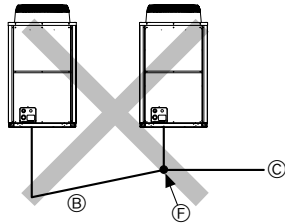
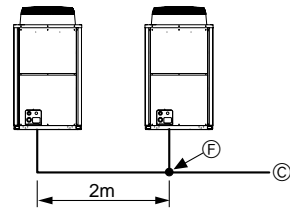
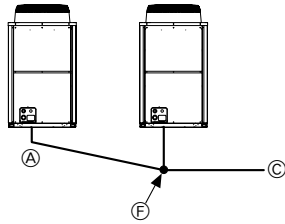

<A> Make sure the pipes from the twinning pipe to the outdoor unit are sloped downwards (towards the twinning pipes).

 When the piping on the outdoor unit side (from the twinning pipe) exceeds 2 m, ensure a trap (gas pipe only) within 2 m.

<C> Slope of twinning pipes

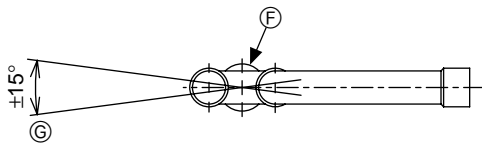

<D> Pipe connection example

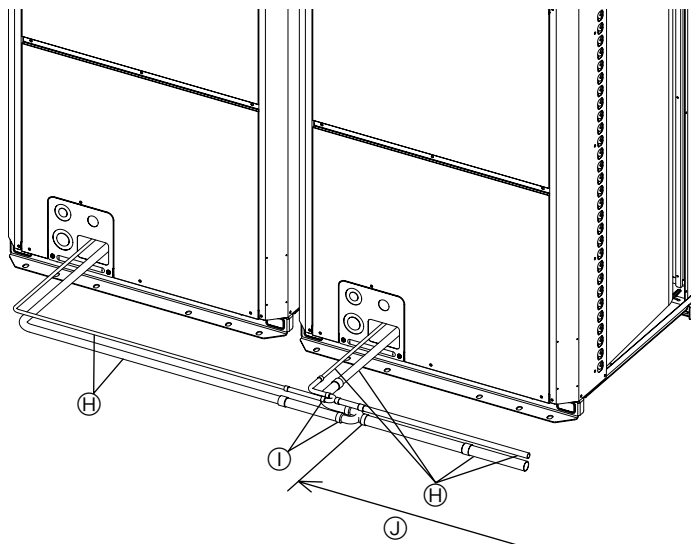

- Ⓐ: Downward slope
- Ⓑ: Upward slope
- Ⓒ: Indoor unit
- Ⓓ: Trap (gas pipe only)
- Ⓔ: Within 2 m
- Ⓕ: Twinning pipe
- Ⓖ: Slope of the twinning pipe is at an angle within $\pm 15^\circ$ to the ground
- Ⓗ: Pipes on site
- Ⓘ: Twinning kit
- Ⓙ: Straight run of pipe that is 500 mm or more

[Fig. 10.2.1]

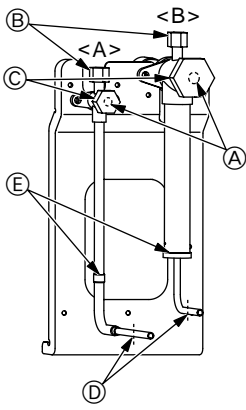

- <A> Refrigerant service valve (liquid side/brazed type)
- Refrigerant service valve (gas side/brazed type)
- Ⓐ: Shaft
- Ⓑ: Service port
- Ⓒ: Cap
- Ⓓ: Pinched connecting pipe severing portion
- Ⓔ: Pinched connecting pipe brazing portion

[Fig. 10.2.3]

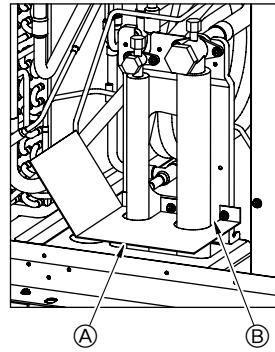

- Ⓐ: Example of closure materials (field supply)
- Ⓑ: Fill the gap at the site

[Fig. 10.2.2]

<A> Front pipe routing

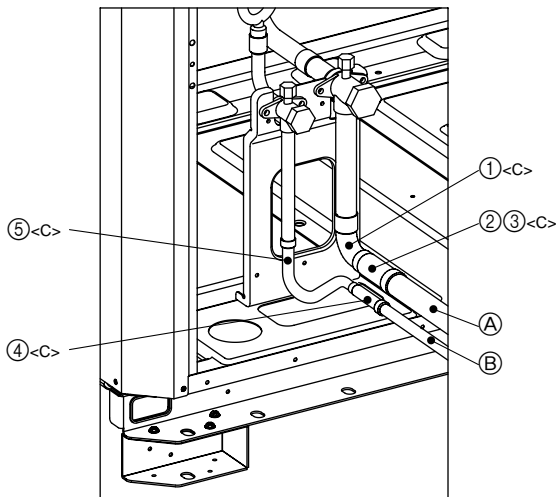

 Bottom pipe routing

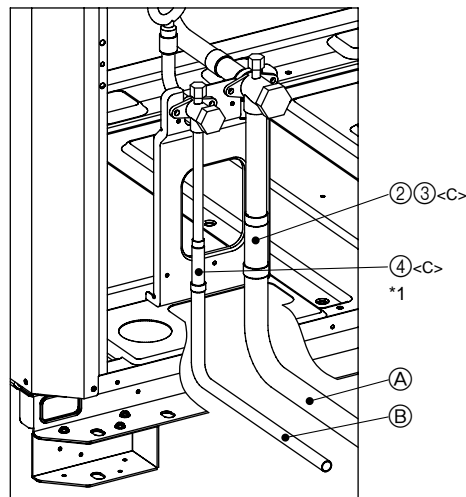

No.	①	③	⑤		
Ⓒ Shape					
No.	②	④			
Ⓒ Shape					
	①	②	③	④	⑤
PUHY-HP200YHM-A	1	1		1	1
PUHY-HP250YHM-A	1		1	1	1

- <A> Front pipe routing
- Bottom pipe routing
- <C> Included with outdoor unit
- Ⓐ Gas pipe (field supply required)
- Ⓑ Liquid pipe (field supply required)
- Ⓒ Shape
- *1 P200, P250: Expand the liquid pipe (ID9.52) and connect directly to the valve. <field supply required>

10.3

[Fig. 10.3.1]

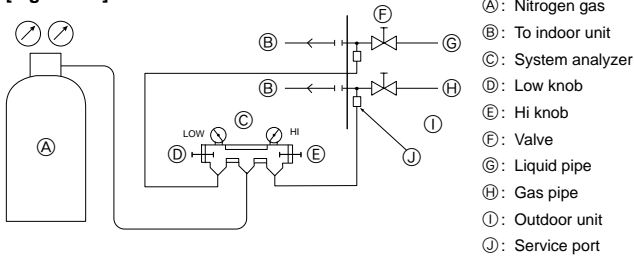

[Fig. 10.3.2]

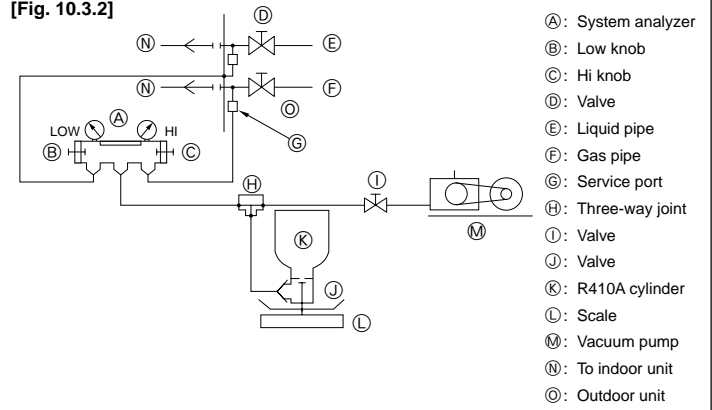

[Fig. 10.3.3]

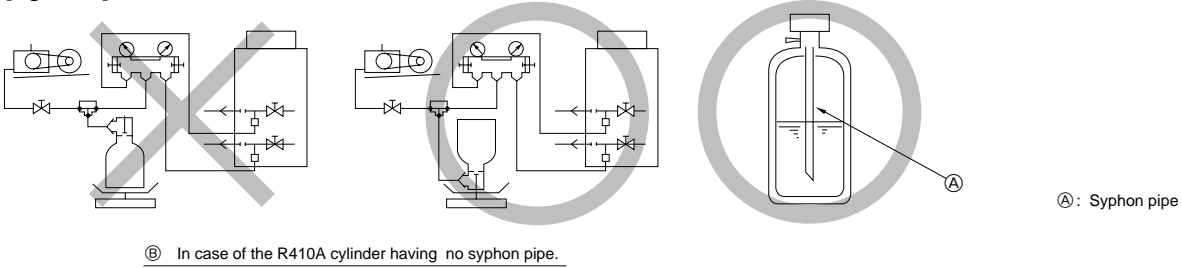

10.4

[Fig. 10.4.1]

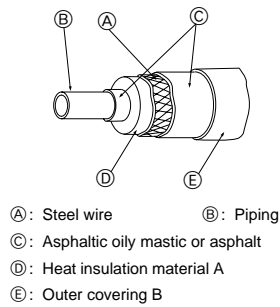

[Fig. 10.4.2]

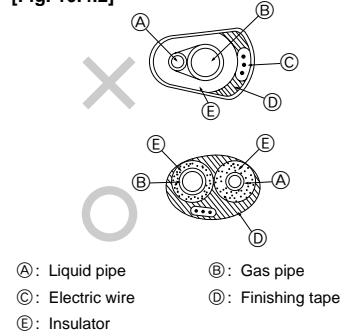

[Fig. 10.4.3]

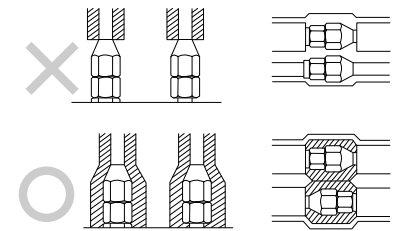

[Fig. 10.4.4]

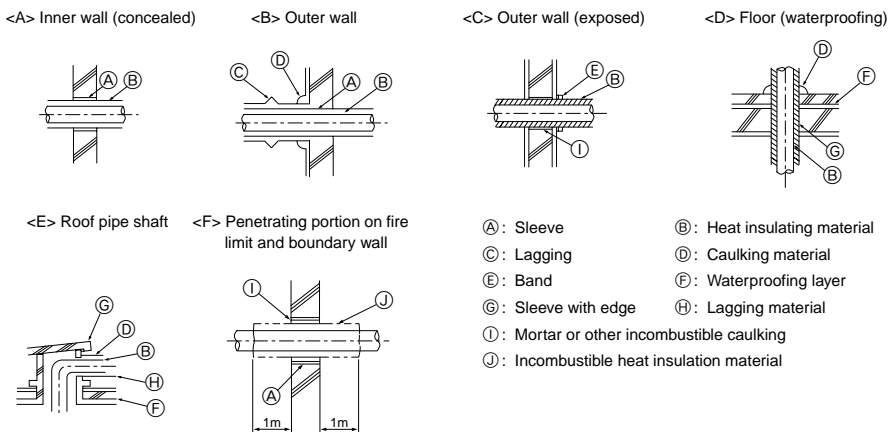

[Fig. 11.2.1]

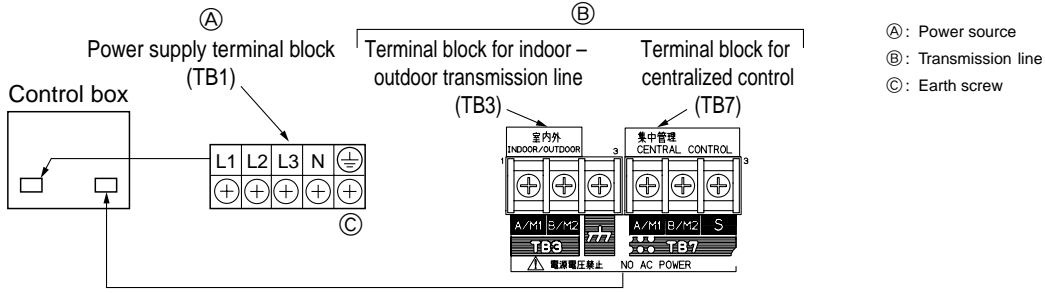

[Fig. 11.2.2]

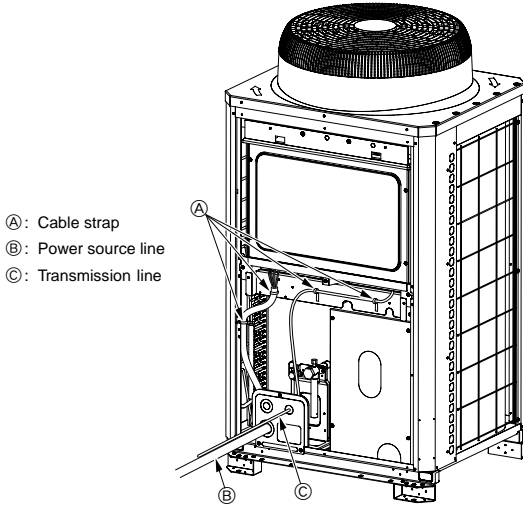

11.3

[Fig. 11.3.1]

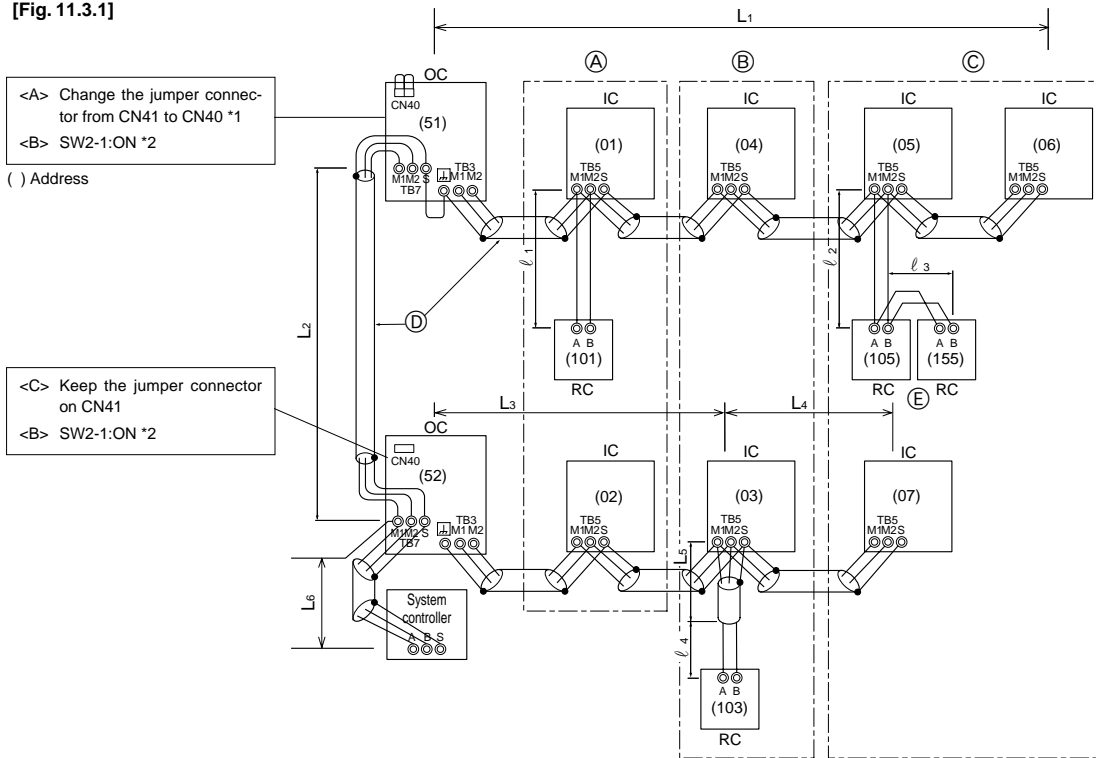

*1: When the power supply unit is not connected to the transmission line for centralized control, disconnect the male power supply connector (CN41) from ONE outdoor unit in the system and connect it to CN40.

*2: If a system controller is used, set SW2-1 on all of the outdoor units to ON.

[Fig. 11.3.2]

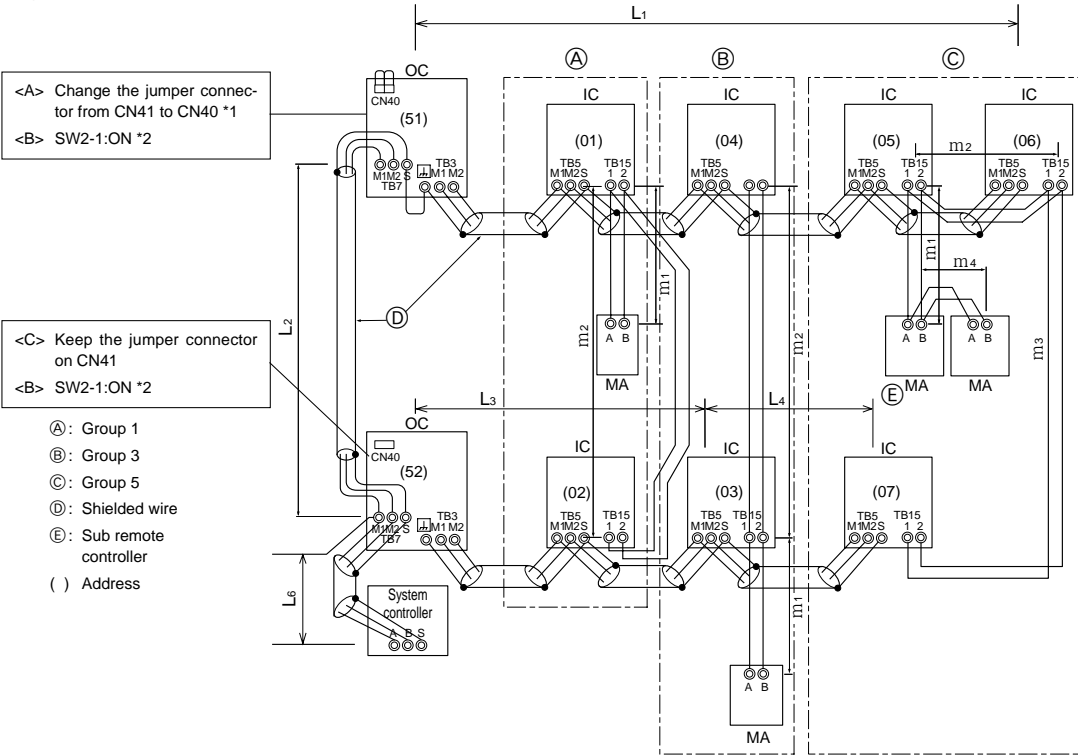

[Fig. 11.3.3]

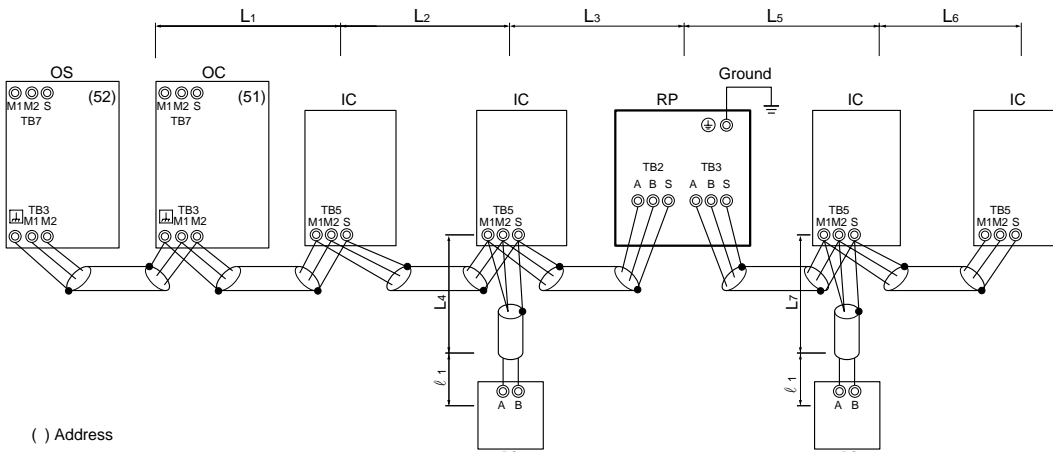

11.4

[Fig. 11.4.1]

- Ⓐ: Switch (Breakers for wiring and current leakage)
- Ⓑ: Breakers for current leakage
- Ⓒ: Outdoor unit
- Ⓓ: Pull box
- Ⓔ: Indoor unit

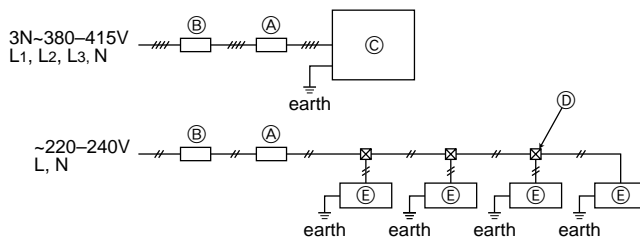

1. Safety precautions	10	10. Additional refrigerant charge	15
1.1. Before installation and electric work	10	10.1. Calculation of additional refrigerant charge	15
1.2. Precautions for devices that use R410A refrigerant	10	10.2. Precautions concerning piping connection and valve operation	15
1.3. Before installation	11	10.3. Airtight test, evacuation, and refrigerant charging	17
1.4. Before installation (relocation) - electrical work	11	10.4. Thermal insulation of refrigerant piping	17
1.5. Before starting the test run	11	11. Wiring (For details, refer to the installation manual of each unit and controller.)	18
2. About the product	11	11.1. Caution	18
3. Combination of outdoor units	12	11.2. Control box and connecting position of wiring	18
4. Specifications	12	11.3. Wiring transmission cables	18
5. Confirmation of parts attached	12	11.4. Wiring of main power supply and equipment capacity	20
6. Space required around unit	12	12. Test run	21
7. Lifting method	12	12.1. The following phenomena do not represent faults.	21
8. Installation of unit	13	13. Information on rating plate	21
8.1. Installation	13		
9. Refrigerant piping installation	13		
9.1. Caution	13		
9.2. Refrigerant piping system	15		

1. Safety precautions

1.1. Before installation and electric work





- ▶ Before installing the unit, make sure you read all the “Safety precautions”.
- ▶ The “Safety precautions” provide very important points regarding safety. Make sure you follow them.

Symbols used in the text

 **Warning:**
Describes precautions that should be observed to prevent danger of injury or death to the user.

 **Caution:**
Describes precautions that should be observed to prevent damage to the unit.

Symbols used in the illustrations

-  : Indicates an action that must be avoided.
-  : Indicates that important instructions must be followed.
-  : Indicates a part which must be grounded.
-  : Beware of electric shock. (This symbol is displayed on the main unit label.)
<Color: yellow>

-  **Warning:**
Carefully read the labels affixed to the main unit.

HIGH VOLTAGE WARNING:

- Control box houses high-voltage parts.
- When opening or closing the front panel of the control box, do not let it come into contact with any of the internal components.
- Before inspecting the inside of the control box, turn off the power, keep the unit off for at least 10 minutes, and confirm that the voltage between FT-P and FT-N on INV Board has dropped to DC20V or less. (It takes about 10 minutes to discharge electricity after the power supply is turned off.)

-  **Warning:**
- Ask the dealer or an authorized technician to install the air conditioner.
 - Improper installation by the user may result in water leakage, electric shock, or fire.
 - Install the unit at a place that can withstand its weight.
 - Failure to do so may cause the unit to fall down, resulting in injuries and damage to the unit.
 - Use the specified cables for wiring. Make the connections securely so that the outside force of the cable is not applied to the terminals.
 - Inadequate connection and fastening may generate heat and cause a fire.
 - Prepare for strong winds and earthquakes and install the unit at the specified place.
 - Improper installation may cause the unit to topple and result in injury and damage to the unit.
 - Always use filters and other accessories specified by Mitsubishi Electric.
 - Ask an authorized technician to install the accessories. Improper installation by the user may result in water leakage, electric shock, or fire.
 - Never repair the unit. If the air conditioner must be repaired, consult the dealer.
 - If the unit is repaired improperly, water leakage, electric shock, or fire may result.

- Do not touch the heat exchanger fins.
 - Improper handling may result in injury.
- If refrigerant gas leaks during installation work, ventilate the room.
 - If the refrigerant gas comes into contact with a flame, poisonous gases will be released.
- Install the air conditioner according to this Installation Manual.
 - If the unit is installed improperly, water leakage, electric shock, or fire may result.
- Have all electric work done by a licensed electrician according to “Electric Facility Engineering Standard” and “Interior Wire Regulations” and the instructions given in this manual and always use a dedicated power supply.
 - If the power source capacity is inadequate or electric work is performed improperly, electric shock and fire may result.
- Securely install the outdoor unit terminal cover (panel).
 - If the terminal cover (panel) is not installed properly, dust or water may enter the outdoor unit and fire or electric shock may result.
- When installing and moving the air conditioner to another site, do not charge it with a refrigerant different from the refrigerant specified on the unit.
 - If a different refrigerant or air is mixed with the original refrigerant, the refrigerant cycle may malfunction and the unit may be damaged.
- If the air conditioner is installed in a small room, measures must be taken to prevent the refrigerant concentration from exceeding the safety limit if the refrigerant should leak.
 - Consult the dealer regarding the appropriate measures to prevent the safety limit from being exceeded. Should the refrigerant leak and cause the safety limit to be exceeded, hazards due to lack of oxygen in the room could result.
- When moving and reinstalling the air conditioner, consult the dealer or an authorized technician.
 - If the air conditioner is installed improperly, water leakage, electric shock, or fire may result.
- After completing installation work, make sure that refrigerant gas is not leaking.
 - If the refrigerant gas leaks and is exposed to a fan heater, stove, oven, or other heat source, it may generate noxious gases.
- Do not reconstruct or change the settings of the protection devices.
 - If the pressure switch, thermal switch, or other protection device is shorted or operated forcibly, or parts other than those specified by Mitsubishi Electric are used, fire or explosion may result.
- To dispose of this product, consult your dealer.
- The installer and system specialist shall secure safety against leakage according to local regulation or standards.
 - The size of the wire and capacities of the switch for the main power supply are applicable if local regulations are not available.
- Pay special attention to the place of installation, such as a basement, etc. where refrigeration gas can accumulate, since refrigeration is heavier than the air.
- For outdoor units that allow fresh air intake to the indoor unit, the installation site must be carefully chosen because outdoor air can directly blow into the room when the thermostat is turned off.
 - Direct exposure to outdoor air may have harmful effects on people or food.

1.2. Precautions for devices that use R410A refrigerant

-  **Caution:**
- Do not use existing refrigerant piping.
 - The old refrigerant and refrigerator oil in the existing piping contains a large amount of chlorine which may cause the refrigerator oil of the new unit to deteriorate.
 - R410A is a high-pressure refrigerant and can cause the existing piping to burst.

- **Use refrigerant piping made of phosphorus deoxidized copper and copper alloy seamless pipes and tubes. In addition, be sure that the inner and outer surfaces of the pipes are clean and free of hazardous sulphur, oxides, dust/dirt, shaving particles, oils, moisture, or any other contaminant.**
 - Contaminants on the inside of the refrigerant piping may cause the refrigerant residual oil to deteriorate.
- **Store the piping to be used during installation indoors and keep both ends of the piping sealed until just before brazing. (Store elbows and other joints in a plastic bag.)**
 - If dust, dirt, or water enters the refrigerant cycle, deterioration of the oil and compressor failure may result.
- **Apply a small amount of ester oil, ether oil, or alkyl benzene to flares. (for indoor unit)**
 - Infiltration of a large amount of mineral oil may cause the refrigerant oil to deteriorate.
- **Use liquid refrigerant to fill the system.**
 - If gas refrigerant is used to fill the system, the composition of the refrigerant in the cylinder will change and performance may drop.
- **Do not use a refrigerant other than R410A.**
 - If another refrigerant (R22, etc.) is mixed with R410A, the chlorine in the refrigerant may cause the refrigerant oil to deteriorate.
- **Use a vacuum pump with a reverse flow check valve.**
 - The vacuum pump oil may flow back into the refrigerant cycle and cause the refrigerant oil to deteriorate.
- **Do not use the following tools that are used with conventional refrigerants.**

(Gauge manifold, charge hose, gas leak detector, reverse flow check valve, refrigerant charge base, refrigerant recovery equipment)

 - If the conventional refrigerant and refrigerator oil are mixed in the R410A, the refrigerant may deteriorate.
 - If water is mixed in the R410A, the refrigerator oil may deteriorate.
 - Since R410A does not contain any chlorine, gas leak detectors for conventional refrigerants will not react to it.
- **Do not use a charging cylinder.**
 - Using a charging cylinder may cause the refrigerant to deteriorate.
- **Be especially careful when managing the tools.**
 - If dust, dirt, or water gets into the refrigerant cycle, the refrigerant may deteriorate.
- **Never connect in reverse phases.**
- **Never connect the Power Line L1, L2, and L3 to Terminal N.**
 - If the unit is miss wired, when power is supplied, some electrical parts will be damaged.
- **Install the power cable so that tension is not applied to the cable.**
 - Tension may cause the cable to break and generate heat and cause a fire.
- **Install a leak circuit breaker, as required.**
 - If a leak circuit breaker is not installed, electric shock may result.
- **Use power line cables of sufficient current carrying capacity and rating.**
 - Cables that are too small may leak, generate heat, and cause a fire.
- **Use only a circuit breaker and fuse of the specified capacity.**
 - A fuse or circuit breaker of a larger capacity, or the use of a substitute simple steel or copper wire may result in a general unit failure or fire.
- **Do not wash the air conditioner units.**
 - Washing them may cause an electric shock.
- **Be careful that the installation base is not damaged by long use.**
 - If the damage is left uncorrected, the unit may fall and cause personal injury or property damage.
- **Install the drain piping according to this Installation Manual to ensure proper drainage. Wrap thermal insulation around the pipes to prevent condensation.**
 - Improper drain piping may cause water leakage causing damage to furniture and other possessions.
- **Be very careful about transporting the product.**
 - One person should not carry the product. Its weight is in excess of 20kg.
 - Some products use PP bands for packaging. Do not use any PP bands as a means of transportation. It is dangerous.
 - Do not touch the heat exchanger fins. Doing so may cut your fingers.
 - When transporting the outdoor unit, support it at the specified positions on the unit base. Also support the outdoor unit at four points so that it cannot slip sideways.
- **Safely dispose of the packing materials.**
 - Packing materials, such as nails and other metal or wooden parts, may cause stabs or other injuries.
 - Tear apart and throw away plastic packaging bags so that children will not play with them. If children play with a plastic bag which has not been torn apart, they face the risk of suffocation.

1.3. Before installation

Caution:

- **Do not install the unit where combustible gas may leak.**
 - If the gas leaks and accumulates around the unit, an explosion may result.
- **Do not use the air conditioner where food, pets, plants, precision instruments, or artwork are kept.**
 - The quality of the food, etc. may deteriorate.
- **Do not use the air conditioner in special environments.**
 - Oil, steam, sulfuric smoke, etc. can significantly reduce the performance of the air conditioner or damage its parts.
- **When installing the unit in a hospital, communication station, or similar place, provide sufficient protection against noise.**
 - Inverter equipment, private power generator, high-frequency medical equipment, or radio communication equipment may cause the air conditioner to operate erroneously, or fail to operate. On the other hand, the air conditioner may affect such equipment by creating noise that disturbs medical treatment or image broadcasting.
- **Do not install the unit on a structure that may cause leakage.**
 - When the room humidity exceeds 80% or when the drain pipe is clogged, condensation may drip from the indoor unit. Perform collective drainage work together with the outdoor unit, as required.

1.4. Before installation (relocation) - electrical work

Caution:

- **Ground the unit.**
 - Do not connect the ground wire to gas or water pipes, lightning rods, or telephone ground lines. Improper grounding may result in electric shock.

2. About the product

- This unit uses R410A-type refrigerant.
- Piping for systems using R410A may be different from that for systems using conventional refrigerant because the design pressure in systems using R410A is higher. Refer to the Data Book for more information.
- Some of the tools and equipment used for installation with systems that use other types of refrigerant cannot be used with the systems using R410A. Refer to the Data Book for more information.

1.5. Before starting the test run

Caution:

- **Turn on the power at least 12 hours before starting operation.**
 - Starting operation immediately after turning on the main power switch can result in irreversible damage to internal parts. Keep the power switch turned on during the operational season. Make sure of the phase order of power supply and voltage between each phase.
- **Do not touch the switches with wet fingers.**
 - Touching a switch with wet fingers can result in an electric shock.
- **Do not touch the refrigerant pipes during and immediately after operation.**
 - During and immediately after operation, the refrigerant pipes may be hot or cold, depending on the condition of the refrigerant flowing through the refrigerant piping, compressor, and other refrigerant cycle parts. Your hands may suffer burns or frostbite if you touch the refrigerant pipes.
- **Do not operate the air conditioner with the panels and guards removed.**
 - Rotating, hot, or high-voltage parts can cause injuries.
- **Do not turn off the power immediately after stopping operation.**
 - Always wait at least 5 minutes before turning off the power. Otherwise, drainage water leakage or mechanical failure of sensitive parts may occur.
- **Do not touch the surface of the compressor during servicing.**
 - If unit is connected to a supply and not running, the crank case heater located at the base of the compressor may still be operating.

Caution:

- **Do not vent R410A into the atmosphere.**
- **R410A is a Fluorinated Greenhouse gas, covered by the Kyoto Protocol with a Global Warming Potential (GWP) = 1975.**

3. Combination of outdoor units

Component units of PUHY-HP400 to HP500 are listed below.

Outdoor unit model	Component unit models	
PUHY-HP200YHM-A(-BS)	-	-
PUHY-HP250YHM-A(-BS)	-	-
PUHY-HP400YSHM-A(-BS)	PUHY-HP200YHM-A(-BS)	PUHY-HP200YHM-A(-BS)
PUHY-HP500YSHM-A(-BS)	PUHY-HP250YHM-A(-BS)	PUHY-HP250YHM-A(-BS)

* PUHY-HP400/500YSHM-A(-BS) require "Twinning Kit" to connect component unit modules in the field.

4. Specifications

Model	PUHY-HP200YHM-A	PUHY-HP250YHM-A	PUHY-HP400YSHM-A	PUHY-HP500YSHM-A
Sound level (60Hz)	56dB <A>	57dB <A>	59dB <A>	60dB <A>
External static pressure	0 Pa*2			
Indoor units	Total capacity			
	50 ~ 130%*1			
	Model			
	15 ~ 250			
	Quantity	1 ~ 17	1 ~ 21	1 ~ 34
Operation temperature	Standard type	Cooling mode: - 5°CDB ~ 43°CDB (0°CDB ~ 43°CDB with outdoor unit at lower position)		
		Heating mode: - 25°CWB ~ 15.5°CWB		
	Outside air intake type	Cooling mode: 21°CDB/15.5°CWB ~ 43°CDB/35°CWB		
		Heating mode: - 10°CDB ~ 20°CDB		

*1: The total indoor capacity of units run simultaneously is 130% or less.

*2: To enable high static pressure, set the DipSW on the main panel as follows.

SW3-9: ON, SW3-10 60Pa compatible: OFF, 30Pa compatible: ON

5. Confirmation of parts attached

- This unit includes the following parts. Please check.
- For usage methods, refer to item 10.2.

Model		① Connecting elbow (brazed)	② Connecting pipe (brazed)	③ Connecting pipe (brazed)	④ Connecting pipe (brazed)	⑤ Connecting pipe (brazed)
		<Gas side>	<Gas side>	<Gas side>	<Liquid side>	<Liquid side>
P200	P200	1 pc.	1 pc.	-	1 pc.	1 pc.
	P250	1 pc.	-	1 pc.	1 pc.	1 pc.

6. Space required around unit

① In case of single installation

- Secure enough space around the unit as shown in the figure on page 2.

[Fig. 6.0.1] (P.2)

- <A> Top view
- Side view
- <C> When there is little space up to an obstruction
- Ⓐ Front
- Ⓑ Unit height
- Ⓒ Back
- Ⓓ Air outlet guide (Procured at the site)

- If the distance is 300 mm or more between the rear side and the wall
- If the distance is 100 mm or more between the rear side and the wall
- If the wall height (H) of the front, rear or side exceeds the wall height restriction
 - When the height of the walls on the front, back or on the sides <H> exceeds the wall height limit as defined here, add the height that exceeds the height limit <h> to the figures that are marked with an asterisk.

<Wall height limit> Front: Up to the unit height
Back: Up to 500 mm from the unit bottom
Side: Up to the unit height

(4) If there are obstacles at the upper part of the unit

② In case of collective installation

[Fig. 6.0.2] (P.2)

- Ⓐ Front
- Ⓑ Must be open
- Ⓒ Wall height (H)

- When multiple units are installed adjacent to each other, secure enough space to allow for air circulation and walkway between groups of units as shown in the figures on page 2.
- At least two sides must be left open.
- As with the single installation, add the height that exceeds the height limit <h> to the figures that are marked with an asterisk.

7. Lifting method

[Fig. 7.0.1] (P.2)

- Use suspension ropes that will withstand the weight of the unit.
- When moving the unit, use a **4-point suspension**, and avoid giving impacts to the unit (Do not use **2-point suspension**).
- Place protective pads on the unit where it comes in contact with the ropes to protect the unit from being scratched.
- Set the angle of roping at 40° or less.
- Use 2 ropes that are each longer than 8 meters.

- Place protective padding at the corners of the product to protect the product from scratches or dents that might be caused by the rope.

⚠ Caution:

Be very careful when carrying/moving the product.

- When installing the outdoor unit, suspend the unit at the specified location of the unit base. Stabilize as necessary so that it does not move to the side and support it at 4 points. If the unit is installed or suspended with 3-point support, the unit may become unstable and fall.

8. Installation of unit

8.1. Installation

[Fig. 8.1.1] (P.3)

- <A> Without detachable leg With detachable leg
- Ⓐ M10 anchor bolt procured at the site. Ⓑ Corner is not seated.
- Ⓒ Fixing bracket for the hole-in anchor bolt (3 locations to fix with screws).
- Ⓓ Detachable leg

- Fix unit tightly with bolts so that unit will not fall down due to earthquakes or strong winds.
- Use concrete or an angle bracket as the foundation of unit.
- Vibration may be transmitted to the installation section and noise and vibration may be generated from the floor and walls, depending on the installation conditions. Therefore, provide ample vibrationproofing (cushion pads, cushion frame, etc.).
- Build the foundation in such way that the corner of the installation leg is securely supported as shown in the figure. (Fig. 8.1.1)
When using a rubber isolating cushion, please ensure it is large enough to cover the entire width of each of the unit's legs. If the corners are not firmly seated, the installation feet may be bent.
- The projecting length of the anchor bolt should be less than 30 mm.
- Hole-in anchor bolts are not compatible with this product. However, if fixing brackets are mounted on the 4 locations of the unit attachment part, hole-in anchor bolts can be used.

[Fig. 8.1.2] (P.3)

- Ⓐ Screws

- The detachable leg can be removed at the site.
- Detaching the detachable leg
Loosen the three screws to detach the detachable leg (Two each in the front and back).
If the base leg finish is damaged when detaching, be sure to repair at the site.

[Fig. 8.1.3] (P.3)

- Ⓐ Inlet
- Ⓑ Outlet

- In abnormally harsh environments such as cold and/or windy areas, sufficient countermeasures to guard against excessive wind and snow should be taken to ensure the unit's correct operation. When the unit is expected to operate in cooling mode in conditions under 10°C, in snowy areas, in environments subject to strong winds or rain, install air inlet and outlet ducting as shown in [Fig. 8.1.3].
- When the unit is expected to operate continuously for an extended period of time in outside temperatures below 0°C, take appropriate measures, such as the use of a unit base heater, to prevent icing on the unit base.

Note:

- Height of frame base for snow damage prevention (H) shall be twice as high as expected snowfall. Width of frame base shall not exceed that of the unit. The frame base shall be made of angle steel, etc., and designed so that snow and wind slip through the structure. (If frame base is too wide, snow will be accumulated on it.)
- Install unit so that wind will not directly lash against openings of inlet and outlet ducts.
- Build frame base at customer referring to this figure.
Material : Galvanized steel plate 1.2T
Painting : Overall painting with polyester powder
Color : Munsell 5Y8/1 (same as that of unit)
- When the unit is used in a cold region and the heating operation is continuously performed for a long time when the outside air temperature is below freezing, install a heater to the unit base or take other appropriate measures to prevent water from freezing on the base.

Warning:

- Be sure to install unit in a place strong enough to withstand its weight. Any lack of strength may cause unit to fall down, resulting in a personal injury.**
- Have installation work in order to protect against strong winds and earthquakes. Any installation deficiency may cause unit to fall down, resulting in a personal injury.**

When building the foundation, give full attention to the floor strength, drain water disposal <during operation, drain water flows out of the unit>, and piping and wiring routes.

Precautions when routing the pipes and wires below the unit (Without detachable leg)

When routing the pipes and wires below the unit, be sure that the foundation and base work do not block the base through-holes. Also make sure the foundation is at least 100 mm high so that the piping can pass under the unit.

9. Refrigerant piping installation

The pipe is connected via a terminal-branch type connection in which refrigerant piping from the outdoor unit is branched at the terminal and is connected to each of the indoor units.

The method of pipe connection is as follows: flare connection for the indoor units, gas pipes and liquid pipes for outdoor units, brazed connection. Note that the branched sections are brazed.

Warning:

Always use extreme care to prevent the refrigerant gas from leaking while using fire or flame. If the refrigerant gas comes in to contact with a flame from any source, such as a gas stove, it breaks down and generates a poisonous gas which can cause gas poisoning. Never weld in an unventilated room. Always conduct an inspection for gas leakage after installation of the refrigerant piping has been completed.

Caution:

- Do not vent R410A into the atmosphere.**
- R410A is a Fluorinated Greenhouse gas, covered by the Kyoto Protocol with a Global Warming Potential (GWP) = 1975.**

9.1. Caution

This unit uses refrigerant R410A. Follow the local regulations on materials and pipe thickness when selecting pipes. (Refer to the table on the right.)

- Use the following materials for refrigeration piping.
 - Material: Use copper alloy seamless pipes made of phosphorus deoxidized copper. Ensure the inner and outer surfaces of the pipes are clean and free from hazardous sulfur, oxide, dusts, shaving particles, oils, and moisture (contamination).
 - Size: Refer to item 9.2. for detailed information on refrigerant piping system.

- Commercially available piping often contains dust and other materials. Always blow it clean with a dry inert gas.
- Use care to prevent dust, water or other contaminants from entering the piping during installation.
- Reduce the number of bending portions as much as possible, and make bending radii as big as possible.
- For indoor and outdoor branching, be sure to use the following twinning pipe sets (sold separately).

Copper pipe size and radial thickness for R410A CITY MULTI.

Size (mm)	Size (inch)	Radial thickness (mm)	Pipe type
ø6.35	ø1/4"	0.8	Type-O
ø9.52	ø3/8"	0.8	Type-O
ø12.7	ø1/2"	0.8	Type-O
ø15.88	ø5/8"	1.0	Type-O
ø19.05	ø3/4"	1.2	Type-O
ø19.05	ø3/4"	1.0	Type-1/2H or H
ø22.2	ø7/8"	1.0	Type-1/2H or H
ø25.4	ø1"	1.0	Type-1/2H or H
ø28.58	ø1-1/8"	1.0	Type-1/2H or H
ø31.75	ø1-1/4"	1.1	Type-1/2H or H
ø34.93	ø1-3/8"	1.2	Type-1/2H or H
ø41.28	ø1-5/8"	1.4	Type-1/2H or H

* For pipe sized ø19.05 (3/4") for R410A air conditioner, choice of pipe type is up to you.

Indoor twinning pipe set model						Outdoor Twinning Kit model
Line branch			Header branch			
Downstream indoor unit capacity Less than 200 in total	Downstream indoor unit capacity More than 201 and less than 400 in total	Downstream indoor unit capacity More than 401 and less than 650 in total	4 branches	8 branches	10 branches	Total outdoor model P400 ~ P500
CMY-Y102S-G2	CMY-Y102L-G2	CMY-Y202-G2	CMY-Y104-G	CMY-Y108-G	CMY-Y1010-G	CMY-Y100VBK2

- ⑥ Use a fitting if a specified refrigerant pipe has a different diameter from that of a branching pipe.
- ⑦ Always observe the restrictions on the refrigerant piping (such as rated length, height difference, and piping diameter) to prevent equipment failure or a decline in heating/cooling performance.
- ⑧ Branching cannot be made after header branching (corresponding parts are marked with X in the diagram below).

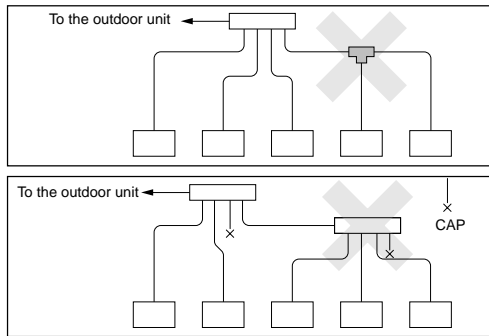

- ⑨ Either a lack or an excess of refrigerant causes the unit to make an emergency stop. Charge the system with an appropriate amount of refrigerant. When servicing, always check the notes concerning pipe length and amount of additional refrigerant at both locations, the refrigerant volume calculation table on the back of the service panel and the additional refrigerant section on the labels for the combined number of indoor units (Refer to item 9.2. for detailed information on refrigerant piping system).
- ⑩ **Be sure to charge the system using liquid refrigerant.**
- ⑪ **Never use refrigerant to perform an air purge.** Always evacuate using a vacuum pump.
- ⑫ Always insulate the piping properly. Insufficient insulation will result in a decline in heating/cooling performance, water drops from condensation and other such problems (Refer to item 10.4 for thermal insulation of refrigerant piping).
- ⑬ When connecting the refrigerant piping, make sure the valve of the outdoor unit is completely closed (the factory setting) and do not operate it until the refrigerant piping for the outdoor and indoor units has been connected, a refrigerant leakage test has been performed and the evacuation process has been completed.
- ⑭ **Braze only with non-oxide brazing material for piping. Failure to do so may damage the compressor. Be sure to perform the non-oxidation brazing with a nitrogen purge.**
Do not use any commercially available anti-oxidizing agent since it may cause pipe corrosion and degrading of the refrigerant oil.
Please contact Mitsubishi Electric for more details.
 (Refer to item 10.2. for details of the piping connection and valve operation)
- ⑮ **Never perform outdoor unit piping connection work when it is raining.**

⚠ Warning:

When installing and moving the unit, do not charge the system with any other refrigerant other than the refrigerant specified on the unit.

- Mixing of a different refrigerant, air, etc. may cause the refrigerant cycle to malfunction and may result in severe damage.

⚠ Caution:

- **Use a vacuum pump with a reverse flow check valve.**
 - If the vacuum pump does not have a reverse flow check valve, the vacuum pump oil may flow back into the refrigerant cycle and cause deterioration of the refrigerant oil.
- **Do not use the tools shown below used with conventional refrigerant. (Gauge manifold, charge hose, gas leak detector, check valve, refrigerant charge base, vacuum gauge, refrigerant recovery equipment)**
 - Mixing of conventional refrigerant and refrigerator oil may cause the refrigerator oil to deteriorate.
 - Mixing of water will cause the refrigerator oil to deteriorate.
 - R410A refrigerant does not contain any chlorine. Therefore, gas leak detectors for conventional refrigerants will not react to it.
- **Manage the tools used for R410A more carefully than normal.**
 - If dust, dirt, or water gets in the refrigerant cycle, the refrigerator oil will deteriorate.
- **Never use existing refrigerant piping.**
 - The large amount of chlorine in conventional refrigerant and refrigerator oil in the existing piping will cause the new refrigerant to deteriorate.
- **Store the piping to be used during installation indoors and keep both ends of the piping sealed until just before brazing.**
 - If dust, dirt, or water gets into the refrigerant cycle, the oil will deteriorate and the compressor may fail.
- **Do not use a charging cylinder.**
 - Using a charging cylinder may cause the refrigerant to deteriorate.
- **Do not use special detergents for washing piping.**

9.2. Refrigerant piping system

Connection example

[Fig. 9.2.1] (P.3, 4)

- Ⓐ Outdoor unit
- Ⓑ Branch
- Ⓒ Indoor unit
- Ⓓ Cap
- Ⓔ Outdoor twinning kit

*1 The pipe sizes listed in columns A1 to A3 in this table correspond to the sizes for the models listed in the unit 1, 2, and 3 columns. When the order of the models for unit 1, 2, and 3 change, make sure to use the appropriate pipe size.

Precautions for outdoor unit combinations

Refer to [Fig. 9.2.2] for the positioning of twinning pipes.

[Fig. 9.2.2] (P.5)

- <A> Make sure the pipes from the twinning pipe to the outdoor unit are sloped downwards (towards the twinning pipes).
- When the piping on the outdoor unit side (from the twinning pipe) exceeds 2 m, ensure a trap (gas pipe only) within 2 m. Make sure the height of the trap is 200 mm or more.
If there is no trap, oil can accumulate inside the pipe, causing a shortage of oil and may damage the compressor.

<C> Slope of twinning pipes

Make sure the slope of the twinning pipes are at an angle within $\pm 15^\circ$ to the ground.

If the slope exceeds the specified angle, the unit may be damaged.

<D> Pipe connection example

- Ⓐ Downward slope
- Ⓑ Upward slope
- Ⓒ Indoor unit
- Ⓓ Trap (gas pipe only)
- Ⓔ Within 2 m
- Ⓕ Slope of the twinning pipes are at an angle within $\pm 15^\circ$ to the ground
- Ⓖ Pipes on site
- Ⓗ Twinning kit
- Ⓙ Straight run of pipe that is 500 mm or more

10. Additional refrigerant charge

At the time of shipping, the outdoor unit is charged with refrigerant.

This charge does not include the amount needed for extended piping and additional charging of each refrigerant line will be required on site. In order that future servicing may be properly provided, always keep a record of the size and length of each refrigerant line and the amount of additional charge by writing it in the space provided on the outdoor unit.

10.1. Calculation of additional refrigerant charge

- Calculate the amount of additional charge based on the length of the piping extension and the size of the refrigerant line.
- Use the table to the right as a guide to calculating the amount of additional charging and charge the system accordingly.
- If the calculation results in a fraction of less than 0.1 kg, round up to the next 0.1 kg. For example, if the result of the calculation was 11.38 kg, round the result up to 11.4 kg.

<Additional Charge>

Additional refrigerant charge (kg)	=	Liquid pipe size Total length of $\phi 19.05 \times 0.29$ (m) $\times 0.29$ (kg/m)	+	Liquid pipe size Total length of $\phi 15.88 \times 0.2$ (m) $\times 0.2$ (kg/m)	+	Liquid pipe size Total length of $\phi 12.7 \times 0.12$ (m) $\times 0.12$ (kg/m)
		+	Liquid pipe size Total length of $\phi 9.52 \times 0.06$ (m) $\times 0.06$ (kg/m)	+	Liquid pipe size Total length of $\phi 6.35 \times 0.024$ (m) $\times 0.024$ (kg/m)	+

<Example>

Indoor	1: 125	A: $\phi 12.7$	40 m	a: $\phi 9.52$	10 m	} At the conditions below:
	2: 100	B: $\phi 9.52$	10 m	b: $\phi 9.52$	5 m	
	3: 40	C: $\phi 9.52$	15 m	c: $\phi 6.35$	10 m	
	4: 32	D: $\phi 9.52$	10 m	d: $\phi 6.35$	10 m	
	5: 63			e: $\phi 9.52$	10 m	

The total length of each liquid line is as follows:

$\phi 12.7$: A = 40 = 40 m

$\phi 9.52$: B + C + D + a + b + e = 10 + 15 + 10 + 10 + 5 + 10 = 60 m

$\phi 6.35$: c + d = 10 + 10 = 20 m

Therefore,

<Calculation example>

Additional refrigerant charge

$$= 40 \times 0.12 + 60 \times 0.06 + 20 \times 0.024 + 3.5 = 12.4 \text{ kg}$$

Value of α

Total capacity of connecting indoor units	α
Models ~ 80	2.0 kg
Models 81 ~ 160	2.5 kg
Models 161 ~ 330	3.0 kg
Models 331 ~ 390	3.5 kg
Models 391 ~ 480	4.5 kg
Models 481 ~ 630	5.0 kg
Models 631 ~ 650	6.0 kg

10.2. Precautions concerning piping connection and valve operation

- Conduct piping connection and valve operation accurately and carefully.
- **Removing the pinched connecting pipe**
When shipped, a pinched connecting pipe is attached to the on-site liquid and gas valves to prevent gas leakage.
Take the following steps ① through ④ to remove the pinched connecting pipe before connecting refrigerant pipes to the outdoor unit.
 - ① Check that the refrigerant service valve is fully closed (turned clockwise all the way).
 - ② Connect a charging hose to the service port on the liquid/gas refrigerant service valve, and extract the gas in the pipe section between the refrigerant service valve and the pinched connecting pipe (Tightening torque 12 N·m).
 - ③ After vacuuming gas from the pinched connecting pipe, sever the pinched connecting pipe at the location shown in [Fig.10.2.1] and drain the refrigerant.
 - ④ After completing ② and ③ heat the brazed section to remove the pinched connecting pipe.

[Fig. 10.2.1] (P.6)

<A> Refrigerant service valve (liquid side/brazed type)

 Refrigerant service valve (gas side/brazed type)

Ⓐ Shaft

Fully closed at the factory, when connecting the piping, and when vacuuming. Open fully after these operations are completed.

<When opening>

- Turn the shaft counterclockwise with a hexagonal wrench.
- Turn around the shaft until it stops.

<When closing>

- Turn the shaft clockwise with a hexagonal wrench.
- Turn around the shaft until it stops.

Ⓑ Service port

Available for gas venting of the pinched connecting pipe, or vacuuming in the refrigerant pipes on the site.
(Tightening torque 12 N·m)

Ⓒ Cap

Remove the cap before operating the shaft. Be sure to return it to the original position after completing the operation.

Ⓓ Pinched connecting pipe severing portion

Ⓔ Pinched connecting pipe brazing portion

⚠ Warning:

- **The section of the pipe on the unit between the two refrigerant service valves is filled with gas. Extract the gas in the above-mentioned pipe section before heating the brazed section to remove the refrigerant service valve connecting pipe.**
- If the brazed section is heated without first extracting the gas, the pipe may burst or the connecting pipe may blow off causing serious injury.

⚠ Caution:

- **Place a wet towel on the refrigerant service valve before heating the brazed section to keep the temperature of the valve from exceeding 120 °C.**
- **Direct the flame away from the wiring and metal sheets inside the unit to prevent heat damage.**

⚠ Caution:

- Do not vent R410A into the atmosphere.
- R410A is a Fluorinated Greenhouse gas, covered by the Kyoto Protocol, with a Global Warming Potential (GWP) = 1975.

• **Refrigerant pipe connection**

This product includes connecting pipes for front piping and bottom post-piping. (Refer to [Fig.10.2.2])

Check the liquid/gas piping dimensions before connecting the refrigerant pipe. Refer to item 9.2 Refrigerant piping system for piping dimensions.

Make sure that the refrigerant pipe is not touching other refrigerants pipes, unit panels, or base plates.

Be sure to use non-oxidative brazing when connecting pipes.

<Refrigerant piping connection examples>

[Fig.10.2.2] (P.6)

- <A> Front pipe routing
- Bottom pipe routing
- <C> Included with outdoor unit
- Ⓐ Gas pipe (field supply required)
- Ⓑ Liquid pipe (field supply required)
- Ⓒ Shape

• **Front pipe routing**

- ① Connecting elbow (ID ø25.4, OD ø25.4) <Included with outdoor unit>
- ② Connecting pipe (OD ø19.05, ID ø25.4) <Included with outdoor unit>
- ③ Connecting pipe (OD ø22.2, ID ø25.4) <Included with outdoor unit>
- ④ Connecting pipe (OD ø12.7, ID ø9.52) <Included with outdoor unit>
- ⑤ Connecting pipe (ID ø9.52, OD ø9.52) <Included with outdoor unit>

• **Bottom pipe routing**

- ② Connecting pipe (OD ø19.05, ID ø25.4) <Included with outdoor unit>
- ③ Connecting pipe (OD ø22.2, ID ø25.4) <Included with outdoor unit>
- ④ Connecting pipe (OD ø12.7, ID ø9.52) <Included with outdoor unit>

*1 P200, P250: Expand the liquid pipe (ID ø9.52) and connect directly to the valve. <field supply required>

- After evacuation and refrigerant charging, ensure that the handle is fully open. If operating with the valve closed, abnormal pressure will be imparted to the high- or low-pressure side of the refrigerant circuit, giving damage to the compressor, four-way valve, etc.
- Determine the amount of additional refrigerant charge by using the formula, and charge refrigerant additionally through the service port after completing piping connection work.
- After completing work, tighten the service port and cap securely so as not to generate any gas leakage. (Refer to the table on the below for appropriate tightening torque.)

Appropriate tightening torque:

Outer diameter of copper pipe (mm)	Cap (N·m)	Shaft (N·m)	Size of hexagonal wrench (mm)	Service port (N·m)
ø9.52	15	6	4	12
ø12.7	20	9	4	
ø15.88	25	15	6	
ø19.05	25	30	8	
ø25.4	25	30	8	

⚠ Caution:

- **Keep the valve closed until refrigerant charging to the pipes to be added on site has been completed. Opening the valve before charging the refrigerant may cause damage to the unit.**
- **Do not use a leak detection additive.**

[Fig. 10.2.3] (P.6)

- Ⓐ Example of closure materials (field supply)
- Ⓑ Fill the gap at the site

Make sure to seal-off the space around areas where the wires and refrigerant pipes enter the unit to ensure that small animals, rainwater, or snow cannot enter the unit through such openings and cause damage to the unit.

⚠ Caution:

Make sure to seal-off the openings for the pipe and wire retrieval.

- **Small animals, rainwater, or snow entering through the openings may cause damage to the device.**

10.3. Airtight test, evacuation, and refrigerant charging

① Airtight test

Perform with the valve of the outdoor unit closed, and pressurize the connection piping and the indoor unit from the service port provided on the valve of the outdoor unit. (Always pressurize from both the liquid pipe and the gas pipe service ports.)

[Fig. 10.3.1] (P.7)

- | | | |
|----------------|------------------|-------------------|
| Ⓐ Nitrogen gas | Ⓑ To indoor unit | Ⓒ System analyzer |
| Ⓓ Low knob | Ⓔ Hi knob | Ⓕ Valve |
| Ⓔ Liquid pipe | Ⓕ Gas pipe | Ⓖ Outdoor unit |
| Ⓖ Service port | | |

Observe the following restrictions when conducting an air tightness test to prevent negative effects on the refrigerating machine oil. Also, with nonazeotropic refrigerant (R410A), gas leakage causes the composition to change and affects performance. Therefore, perform the airtightness test cautiously.

Airtight test procedure	Restriction
(1) After pressurizing to the design pressure (4.15 MPa) using nitrogen gas, allow it to stand for about one day. If the pressure does not drop, airtightness is good. However, if the pressure drops, since the leaking point is unknown, the following bubble test may also be performed. (2) After the pressurization described above, spray the flare connection parts, brazed parts, and other parts that may leak with a bubbling agent (Kyuboflex, etc.) and visually check for bubbles. (3) After the airtight test, wipe off the bubbling agent.	<ul style="list-style-type: none"> If a flammable gas or air (oxygen) is used as the pressurization gas, it may catch fire or explode.

⚠ Caution:

Only use refrigerant R410A.

- The use of other refrigerants such as R22 or R407C, which contains chlorine, will deteriorate the refrigerating machine oil or cause the compressor to malfunction.

② Evacuation

Evacuate with the valve of the outdoor unit closed and evacuate both the connection piping and the indoor unit from the service port provided on the valve of the outdoor unit using a vacuum pump. (Always evacuate from the service port of both liquid pipe and gas pipe.) After the vacuum reaches 650 Pa [abs], continue evacuation for at least one hour or more. Then, stop the vacuum pump and leave it for 1 hour. Ensure the degree of vacuum has not increased. (If the degree of vacuum increase is larger than 130 Pa, water might have entered. Apply pressure to dry nitrogen gas up to 0.05 MPa and vacuum again.) Finally, seal in with the liquid refrigerant through the liquid pipe, and adjust the gas piping to obtain an appropriate amount of the refrigerant during operation.

* Never perform air purging using refrigerant.

[Fig. 10.3.2] (P.7)

- | | | |
|-------------------|-------------------|----------------|
| Ⓐ System analyzer | Ⓑ Low knob | Ⓒ Hi knob |
| Ⓓ Valve | Ⓔ Liquid pipe | Ⓕ Gas pipe |
| Ⓔ Service port | Ⓕ Three-way joint | Ⓖ Valve |
| Ⓖ Valve | Ⓖ R410A cylinder | Ⓗ Scale |
| Ⓗ Vacuum pump | Ⓗ To indoor unit | Ⓖ Outdoor unit |

Note:

- Always add an appropriate amount of refrigerant. Also always charge the system with liquid refrigerant.
- Use a gauge manifold, charging hose, and other parts for the refrigerant indicated on the unit.
- Use a gravimeter. (One that can measure down to 0.1 kg.)
- Use a vacuum pump with a reverse flow check valve. (Recommended vacuum gauge: ROBINAIR 14830A Thermistor Vacuum Gauge)
 Also use a vacuum gauge that reaches 65 Pa [abs] or below after operating for five minutes.

③ Refrigerant Charging

Since the refrigerant used with the unit is nonazeotropic, it must be charged in the liquid state. Consequently, when charging the unit with refrigerant from a cylinder, if the cylinder does not have a syphon pipe, charge the liquid refrigerant by turning the cylinder upside-down as shown in Fig.10.3.3. If the cylinder has a syphon pipe like that shown in the picture on the right, the liquid refrigerant can be charged with the cylinder standing upright. Therefore, give careful attention to the cylinder specifications. If the unit should be charged with gas refrigerant, replace all the refrigerant with new refrigerant. Do not use the refrigerant remaining in the cylinder.

[Fig. 10.3.3] (P.7)

- | | |
|---------------|--|
| Ⓐ Syphon pipe | Ⓑ In case of the R410A cylinder having no syphon pipe. |
|---------------|--|

10.4. Thermal insulation of refrigerant piping

Be sure to add insulation work to refrigerant piping by covering liquid pipe and gas pipe separately with enough thickness heat-resistant polyethylene, so that no gap is observed in the joint between indoor unit and insulating material, and insulating materials themselves. When insulation work is insufficient, there is a possibility of condensation drip, etc. Pay special attention to insulation work in the ceiling plenum.

[Fig. 10.4.1] (P.7)

- | | |
|------------------------------------|------------------------------|
| Ⓐ Steel wire | Ⓑ Piping |
| Ⓒ Asphaltic oily mastic or asphalt | Ⓓ Heat insulation material A |
| Ⓔ Outer covering B | |

Heat insulation material A	Glass fiber + Steel wire	
	Adhesive + Heat - resistant polyethylene foam + Adhesive tape	
Outer covering B	Indoor	Vinyl tape
	Floor exposed	Water-proof hemp cloth + Bronze asphalt
	Outdoor	Water-proof hemp cloth + Zinc plate + Oily paint

Note:

- When using polyethylene cover as covering material, asphalt roofing shall not be required.
- No heat insulation must be provided for electric wires.

[Fig. 10.4.2] (P.7)

- | | | |
|------------------|-------------|-----------------|
| Ⓐ Liquid pipe | Ⓑ Gas pipe | Ⓒ Electric wire |
| Ⓓ Finishing tape | Ⓔ Insulator | |

[Fig. 10.4.3] (P.7)

Penetrations

[Fig. 10.4.4] (P.7)

- <A> Inner wall (concealed)
- Outer wall
- <C> Outer wall (exposed)
- <D> Floor (waterproofing)
- <E> Roof pipe shaft
- <F> Penetrating portion on fire limit and boundary wall
- Ⓐ Sleeve
- Ⓑ Heat insulating material
- Ⓒ Lagging
- Ⓓ Caulking material
- Ⓔ Band
- Ⓕ Waterproofing layer
- Ⓖ Sleeve with edge
- Ⓖ Lagging material
- Ⓛ Mortar or other incombustible caulking
- Ⓜ Incombustible heat insulation material

When filling a gap with mortar, cover the penetration part with steel plate so that the insulation material will not be caved in. For this part, use incombustible materials for both insulation and covering. (Vinyl covering should not be used.)

- Insulation materials for the pipes to be added on site must meet the following specifications:

	Pipe size	
	ø6.35 to 25.4 mm	ø28.58 to 41.28 mm
Thickness	10 mm min.	15 mm min.
Temperature Resistance	100°C min.	

- * Installation of pipes in a high-temperature high-humidity environment, such as the top floor of a building, may require the use of insulation materials thicker than the ones specified in the chart above.
- * When certain specifications presented by the client must be met, ensure that they also meet the specifications on the chart above.

11. Wiring (For details, refer to the installation manual of each unit and controller.)

11.1. Caution

- Follow ordinance of your governmental organization for technical standard related to electrical equipment, wiring regulations and guidance of each electric power company.
- Wiring for control (hereinafter referred to as transmission line) shall be (5 cm or more) apart from power source wiring so that it is not influenced by electric noise from power source wiring (Do not insert transmission line and power source wire in the same conduit).
- Be sure to provide designated grounding work to the outdoor unit.
- Give some allowance to wiring for electrical part box of indoor and outdoor units, because the box is sometimes removed at the time of service work.
- Never connect the main power source to terminal block of transmission line. If connected, electrical parts will burn out.
- Use 2-core shield cable for transmission line. If transmission lines of different systems are wired with the same multiplex cable, the resultant poor transmitting and receiving will cause erroneous operations.
- Only the transmission line specified should be connected to the terminal block for outdoor unit transmission. Erroneous connection does not allow the system to operate.
- In the case of connecting with an upper class controller or to conduct group operation in different refrigerant systems, the control line for transmission is required between the outdoor units in different refrigerant systems. Connect this control line between the terminal blocks for centralized control (2-wire line with no polarity).
- Group is set by operating the remote controller.

11.2. Control box and connecting position of wiring

- Outdoor unit**
 - Remove the front panel of the control box by removing the 4 screws and pushing it up a little before pulling it out.
 - Connect the indoor - outdoor transmission line to the terminal block (TB3) for the indoor - outdoor transmission line.
If multiple outdoor units are connected in the same refrigerant system, daisy-chain TB3 (M1, M2, ↗ Terminal) on the outdoor units. Connect the indoor - outdoor transmission line for the outdoor units to TB3 (M1, M2, ↗ Terminal) of only one of the outdoor units.
 - Connect the transmission lines for centralized control (between the centralized control system and the outdoor unit of different refrigerant systems) to the terminal block for centralized control (TB7). If the multiple outdoor units are connected to the same refrigerant system, daisy-chain TB7 (M1, M2, S Terminal) on the outdoor units in the same refrigerant system. (*1)
*1: If TB7 on the outdoor unit in the same refrigerant system is not daisy-chained, connect the transmission line for centralized control to TB7 on the OC (*2). If the OC is out of order, or if the centralized control is being conducted during the power supply shut-off, daisy-chain TB7 on the OC, OS1, and OS2 (In the case that the outdoor unit whose power supply connector CN41 on the control board has been replaced with CN40 is out of order or the power is shut-off, centralized control will not be conducted even when TB7 is daisy-chained).
*2: OC, OS1, and OS2 of the outdoor units in the same refrigerant system are automatically identified. They are identified as OC, OS1, and OS2 in descending order of capacity (If the capacity is the same, they will be in ascending order of their address number).

- In the case of indoor-outdoor transmission line, connect the shield ground to the grounding terminal (Ⓛ). In the case of transmission lines for centralized control, connect it to the shield terminal (S) on the terminal block for centralized control (TB7). Furthermore, in the case of the outdoor units whose power supply connector CN41 is replaced with CN40, short circuit the shield terminal (S) and the grounding terminal (Ⓛ) in addition to the above.
- Fix the connected wires securely in place with the cable strap at the bottom of the terminal block. External force applied to the terminal block may damage it resulting in a short circuit, ground fault, or a fire.

[Fig. 11.2.1] (P.8)

- Ⓐ Power source
- Ⓑ Transmission line
- Ⓒ Earth screw

[Fig. 11.2.2] (P.8)

- Ⓐ Cable strap
- Ⓑ Power source line
- Ⓒ Transmission line

② Conduit tube installation

- Close by hammering the knockout holes for the conduit tube located on the base and the bottom part of the front panel.
- When installing the conduit tube directly through the knockout holes, remove the burr and protect the tube with masking tape.
- Use the conduit tube to narrow down the opening if there is a possibility of small animals entering the unit.

11.3. Wiring transmission cables

① Types of control cables

- Wiring transmission cables
 - Types of transmission cables: Shielding wire CVVS, CPEVS or MVVS
 - Cable diameter: More than 1.25 mm²
 - Maximum wiring length: Within 200 m
 - Maximum length of transmission lines for centralized control and indoor/outdoor transmission lines (Maximum length via outdoor units): 500 m MAX
The maximum length of the wiring between power supply unit for transmission lines (on the transmission lines for centralized control) and each outdoor unit and system controller is 200 m.

② Remote control cables

• M-NET Remote Controller

Kind of remote control cable	Sheathed 2-core cable (unshielded) CVV
Cable diameter	0.3 to 1.25 mm ² (0.75 to 1.25 mm ²)*
Remarks	When 10 m is exceeded, use cable with the same specifications as 1. Wiring transmission cables.

• MA Remote Controller

Kind of remote control cable	Sheathed 2-core cable (unshielded) CVV
Cable diameter	0.3 to 1.25 mm ² (0.75 to 1.25 mm ²)*
Remarks	Within 200 m

- * Connected with simple remote controller.

② Wiring examples

- Controller name, symbol and allowable number of controllers.

	Name	Code	Possible unit connections
Outdoor unit	Main unit	OC	- (*2)
	Sub unit	OS1, OS2	- (*2)
Indoor unit	Indoor unit controller	IC	1 to 32 units per 1 OC (*1)
Remote controller	Remote controller (*1)	RC	2 units maximum per group
Other	Transmission booster unit	RP	0 to 1 unit per 1 OC (*1)

*1 A transmission booster (RP) may be required depending on the number of connected indoor unit controllers.

*2 OC, OS1, and OS2 of the outdoor units in the same refrigerant system are automatically identified. They are identified as OC, OS1, and OS2 in descending order of capacity. (If the capacity is the same, they will be in ascending order of their address number.)

Example of a group operation system with multiple outdoor units (Shielding wires and address setting are necessary.)

<Examples of transmission cable wiring>

[Fig. 11.3.1] M-NET Remote Controller (P.8)

[Fig. 11.3.2] MA Remote Controller (P.9)

[Fig. 11.3.3] Combination of outdoor units and transmission booster unit (P.9)

<Wiring Method and Address Settings>

- Always use shielded wire when making connections between the outdoor unit (OC) and the indoor unit (IC), as well for all OC-OC, OC-OS, OS-OS, and IC-IC wiring intervals.
- Use feed wiring to connect terminals M1 and M2 and the earth terminal \perp on the transmission line terminal block (TB3) of each outdoor unit (OC) to terminals M1, M2 and terminal S on the transmission line block of the indoor unit (IC). For OC and OS, connect TB3 to TB3.
- Connect terminals 1 (M1) and 2 (M2) on the transmission line terminal block of the indoor unit (IC) that has the most recent address within the same group to the terminal block on the remote controller (RC).
- Connect together terminals M1, M2 and terminal S on the terminal block for central control (TB7) for the outdoor unit in a different refrigerant system (OC). For OC and OS in the same refrigerant system, connect TB7 to TB7.
- When the power supply unit is not installed on the central control transmission line, change the jumper connector on the control board from CN41 to CN40 on only one outdoor unit in the system.
- Connect the terminal S on the terminal block for central control (TB7) for the outdoor unit (OC) for the unit into which the jumper connector was inserted into CN40 in the step above to the earth terminal \perp in the electrical component box.
- Set the address setting switch as follows.
 - * To set the outdoor unit address to 100, the outdoor address setting switch must be set to 50.

Unit	Range	Setting Method
Indoor unit (Main)	01 to 50	Use the most recent address within the same group of indoor units
Indoor unit (Sub)	01 to 50	Use an address, other than that of the IC (Main) from among the units within the same group of indoor units. This must be in sequence with the IC (Main)
Outdoor Unit (OC, OS)	51 to 100	Set the addresses of the outdoor units in the same refrigerant system in the order of sequential number. OC, OS1, and OS2 are automatically identified. (*1)
M-NET R/C (Main)	101 to 150	Set at an IC (Main) address within the same group plus 100
M-NET R/C (Sub)	151 to 200	Set at an IC (Main) address within the same group plus 150
MA R/C	-	Unnecessary address setting (Necessary main/sub setting)

- The group setting operations among the multiple indoor units is done by the remote controller (RC) after the electrical power has been turned on.
 - When the centralized remote controller is connected to the system, set centralized control switches (SW2-1) on control boards in all outdoor units (OC, OS) to "ON".
- *1 OC, OS1, and OS2 of the outdoor units in the same refrigerant system are automatically identified. They are identified as OC, OS1, and OS2 in descending order of capacity (If the capacity is the same, they are identified in the ascending order of their address number).

<Permissible Lengths>

① M-NET Remote controller

- Max length via outdoor units: $L_1+L_2+L_3+L_4$ and $L_1+L_2+L_3+L_5$ and $L_1+L_2+L_6 \leq 500$ m (1.25 mm² or more)
- Max transmission cable length: L_1 and L_3+L_4 and L_3+L_5 and L_6 and $L_2+L_6 \leq 200$ m (1.25 mm² or more)
- Remote controller cable length: $l_1, l_2, l_3, l_4 \leq 10$ m (0.3 to 1.25 mm²)
If the length exceeds 10 m, use a 1.25 mm² shielded wire. The length of this section (L_a) should be included in the calculation of the maximum length and overall length.

② MA Remote controller

- Max length via outdoor unit (M-NET cable): $L_1+L_2+L_3+L_4$ and $L_1+L_2+L_6 \leq 500$ m (1.25 mm² or more)
- Max transmission cable length (M-NET cable): L_1 and L_3+L_4 and L_6 and $L_2+L_6 \leq 200$ m (1.25 mm² or more)
- Remote controller cable length: m_1+m_2 and $m_1+m_2+m_3+m_4 \leq 200$ m (0.3 to 1.25 mm²)

③ Transmission booster

- Max transmission cable length (M-NET cable):
 - $L_1+L_2+L_3+L_5+L_6 \leq 200$ m (1.25 mm²)
 - $L_1+L_2+L_3+L_5+L_7 \leq 200$ m (1.25 mm²)
 - $L_1+L_2+L_4 \leq 200$ m (1.25 mm²)
 - $L_6+L_5+L_3+L_4, L_4+L_3+L_5+L_7 \leq 200$ m (1.25 mm²)

- Remote controller cable length: $\ell_1, \ell_2 \leq 10$ m (0.3 to 1.25 mm²)
If the length exceeds 10 m, use 1.25 mm² shielded cable and calculate the length of that portion (L4 and L7) as within the total extended length and the longest remote length.

11.4. Wiring of main power supply and equipment capacity

Schematic Drawing of Wiring (Example)

[Fig. 11.4.1] (P.9)

- Ⓐ Switch (Breakers for wiring and current leakage)
- Ⓑ Breakers for current leakage
- Ⓒ Outdoor unit
- Ⓓ Pull box
- Ⓔ Indoor unit

Thickness of wire for main power supply, capacities of the switch and system impedance

	Model	Unit combination	Minimum wire thickness (mm ²)			Switch (A)		Breaker for wiring (NFB) (A)	Breaker for current leakage	Minimum circuit ampacity (MCA) (A)	Max. Permissible System Impedance
			Main cable	Branch	Ground	Capacity	Fuse				
Outdoor unit	PUHY-HP200YHM-A		4.0	-	4.0	32	32	30	30A 100mA 0.1sec. or less	26.3	*1
	PUHY-HP250YHM-A		6.0	-	6.0	40	40	40	40A 100mA 0.1sec. or less	31.5	0.24 Ω
Total operating current of the indoor unit	16A or less		1.5	1.5	1.5	16	16	20	20A 30mA 0.1sec. or less	-	(apply to IEC61000-3-3)
	25A or less		2.5	2.5	2.5	25	25	30	30A 30mA 0.1sec. or less	-	(apply to IEC61000-3-3)
	32A or less		4.0	4.0	4.0	32	32	40	40A 40mA 0.1sec. or less	-	(apply to IEC61000-3-3)

*1: Meets technical requirements of IEC61000-3-3

- Use dedicated power supplies for the outdoor unit and indoor unit. Ensure OC and OS are wired individually.
- Bear in mind ambient conditions (ambient temperature, direct sunlight, rain water, etc.) when proceeding with the wiring and connections.
- The wire size is the minimum value for metal conduit wiring. If the voltage drops, use a wire that is one rank thicker in diameter. Make sure the power-supply voltage does not drop more than 10%.
- Specific wiring requirements should adhere to the wiring regulations of the region.
- Power supply cords of parts of appliances for outdoor use shall not be lighter than polychloroprene sheathed flexible cord (design 245 IEC57). For example, use wiring such as YZW.
- A switch with at least 3 mm contact separation in each pole shall be provided by the Air Conditioner installer.

⚠ Warning:

- Be sure to use specified wires for connections and ensure no external force is imparted to terminal connections. If connections are not fixed firmly, heating or fire may result.
- Be sure to use the appropriate type of overcurrent protection switch. Note that generated overcurrent may include some amount of direct current.

⚠ Caution:

- Some installation sites may require attachment of an earth leakage breaker for the inverter. If no earth leakage breaker is installed, there is a danger of electric shock.
- Do not use anything other than a breaker and fuse with the correct capacity. Using a fuse or wire of too large capacity may cause malfunction or fire.

Note:

- This device is intended for the connection to a power supply system with a maximum permissible system impedance shown in the above table at the interface point (power service box) of the user's supply.
- The user must ensure that this device is connected only to a power supply system which fulfils the requirement above. If necessary, the user can ask the public power supply company for the system impedance at the interface point.
- This equipment complies with IEC 61000-3-12 provided that the short-circuit power S_{sc} is greater than or equal to $S_{sc}(*2)$ at the interface point between the user's supply and the public system. It is the responsibility of the installer or user of the equipment to ensure, by consultation with the distribution network operator if necessary, that the equipment is connected only to a supply with a short-circuit power S_{sc} greater than or equal to $S_{sc}(*2)$.

$S_{sc}(*2)$

Model	S_{sc} (MVA)
PUHY-HP200YHM	1.87
PUHY-HP250YHM	2.24

12. Test run

12.1. The following phenomena do not represent faults.

Phenomenon	Display of remote controller	Cause
Indoor unit does not perform cooling (heating) operation.	"Cooling (heating)" flashes	When another indoor unit is performing the heating (cooling) operation, the cooling (heating) operation is not performed.
The auto vane rotates and begins to blow air horizontally.	Normal display	If air has been blowing downward for 1 hour during cooling, the unit may automatically change to horizontal blowing with the control operation of the auto vane. During defrosting or immediately after heating start-up/shut-down, the auto vane automatically rotates to blow air horizontally for a short period of time.
Fan setting changes during heating.	Normal display	Ultra-low speed operation is commenced at thermostat OFF. Light air automatically changes over to set value by time or piping temperature at thermostat ON.
Fan stops during heating operation.	Defrost display	The fan is to stop during defrosting.
Fan does not stop while operation has been stopped.	No lighting	The fan is set to run for 1 minute after stopping to exhaust residual heat (only in heating).
No setting of fan while start SW has been turned on.	Heat ready	Ultra low-speed operation for 5 minutes after SW ON or until piping temperature becomes 35°C, low speed operation for 2 minutes thereafter, and then set notch is commenced (Hot adjust control).
Indoor unit remote controller shows "H0" or "PLEASE WAIT" indicator for about five minutes when turning ON universal power supply.	"H0" or "PLEASE WAIT" flashes	The system is being started up. Operate remote controller again after "H0" or "PLEASE WAIT" disappear.
Drain pump does not stop when unit is stopped.	Light out	After cooling operation stops, the unit continues to operate drain pump for three minutes and then stops it.
Drain pump continues to operate while unit has been stopped.		Unit continues to operate drain pump if drainage is generated, even during a stop.
Indoor unit emits noise when switching from heating to cooling and vice versa.	Normal display	This is a switching sound of the refrigerant circuit and does not imply a problem.
Immediately after startup, the indoor unit emits the sound of the refrigerant flow.	Normal display	Unstable flow of the refrigerant emits a sound. This is temporary and does not imply a problem.
Warm air comes from an indoor unit that is not performing a heating operation.	Normal display	The LEV is slightly open to prevent refrigerant, of the indoor unit that is not performing the heating operation, from being liquefied. This does not imply a problem.

13. Information on rating plate

Model	HP200	HP250	HP400		HP500	
Unit combination	-	-	HP200	HP200	HP250	HP250
Refrigerant (R410A)	9.0 kg	9.0 kg	9.0 kg	9.0 kg	9.0 kg	9.0 kg
Allowable pressure (Ps)	HP: 4.15 MPa, LP: 2.21 MPa					
Net weight	220 kg	220 kg	220 kg	220 kg	220 kg	220 kg

This product is designed and intended for use in the residential, commercial and light-industrial environment.

The product at hand is based on the following EU regulations:

- Low Voltage Directive 2006/95/EC
- Electromagnetic Compatibility Directive 2004/108/EC
- Pressure Equipment Directive 97/23/EC

Please be sure to put the contact address/telephone number on this manual before handing it to the customer.

 **MITSUBISHI ELECTRIC CORPORATION**

HEAD OFFICE: TOKYO BLDG., 2-7-3, MARUNOUCHI, CHIYODA-KU, TOKYO 100-8310, JAPAN

Authorized representative in EU: MITSUBISHI ELECTRIC EUROPE B.V.

HARMAN HOUSE, 1 GEORGE STREET, UXBRIDGE, MIDDLESEX UB8 1QQ, U.K.